

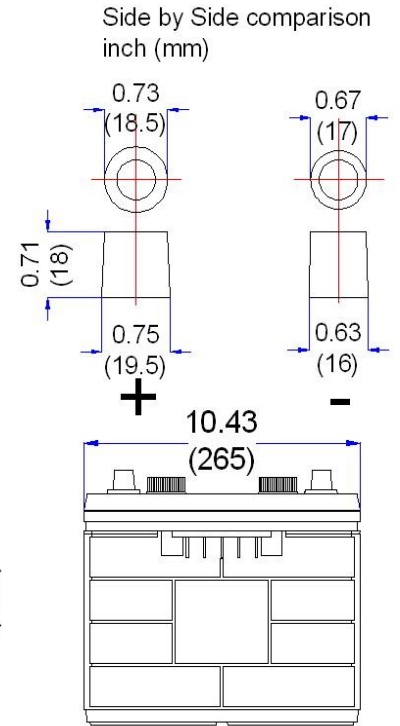

6TL

12V 120AH

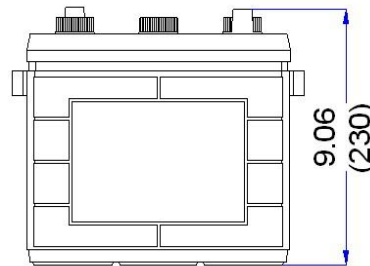
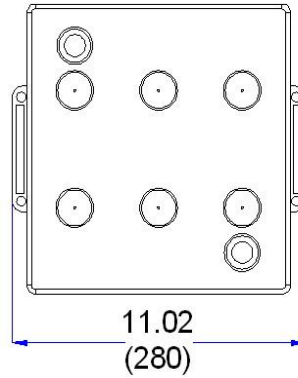

6TL Product Specifications

Type	Capacity Minutes		Cranking Performance		5Hr Rate AH	20Hr Rate AH	Voltage	Dimensions inches(mm)			Weight Lbs (kg)
	@25 Amps	@75 Amps	CCA @-18°C	CA @25°C				L	W	H	
6TL	220	60	650	860	95	120	12	11.02 (280)	10.43 (265)	9.06 (230)	52.36 (23.8)

Characteristics

Internal Resistance	Capacity affected by Temperature (20hour rate)				Charge (Constant Voltage)	
Full Charge Battery 77°F(25°C)	104°F (40°C)	77°F (25°C)	32°F (0°C)	5°F (-15°C)	Float Charge	Equalize Charge
3.7mΩ	102%	100%	85%	64%	13.6V~13.8V	14.7V~15.5V