

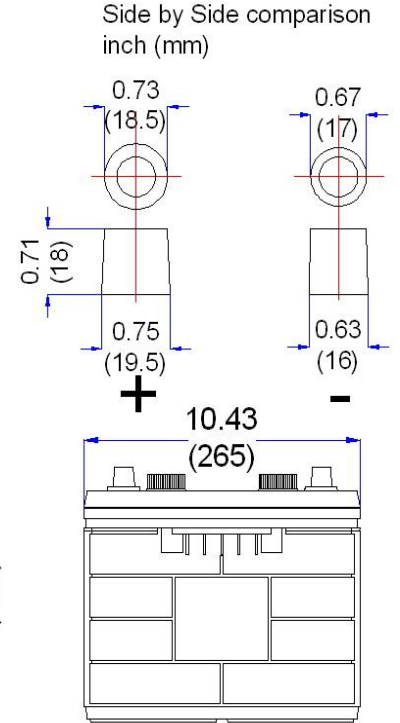

# 6TMF

## 12V 120AH

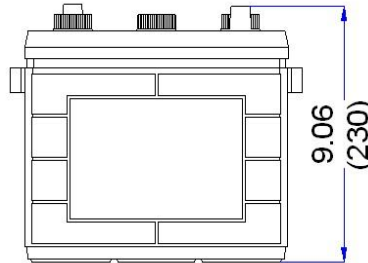
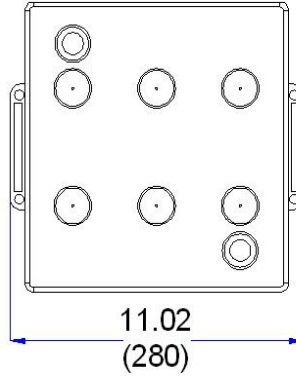

### 6TMF Product Specifications

Type	Capacity Minutes		Cranking Performance		5Hr Rate AH	20Hr Rate AH	Voltage	Dimensions inches(mm)			Weight Lbs (kg)
	@25 Amps	@75 Amps	CCA @-18°C	CA @25°C				L	W	H	
6TMF	240	62	725	860	97	120	12	11.02 (280)	10.43 (265)	9.06 (230)	52.36 (23.8)

### Characteristics

Internal Resistance	Capacity affected by Temperature (20hour rate)				Charge (Constant Voltage)	
	104°F (40°C)	77°F (25°C)	32°F (0°C)	5°F (-15°C)	Float Charge	Equalize Charge
3.7mΩ	102%	100%	85%	64%	13.6V~13.8V	14.7V~15.5V