

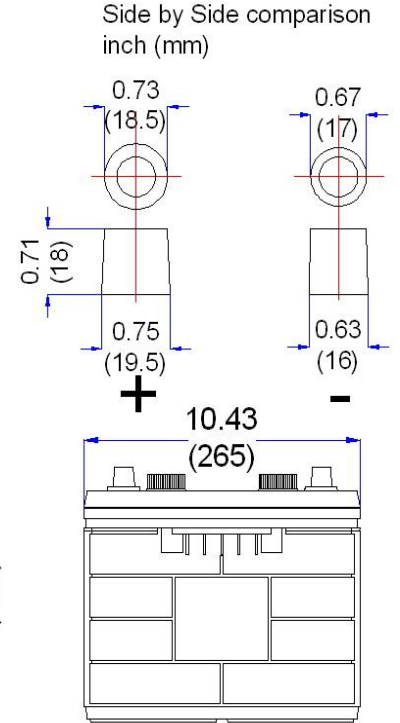

6TN

12V 100AH

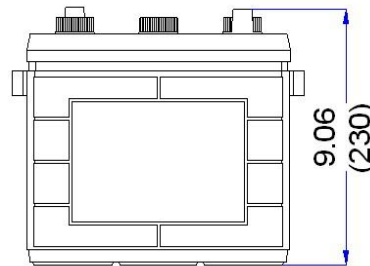
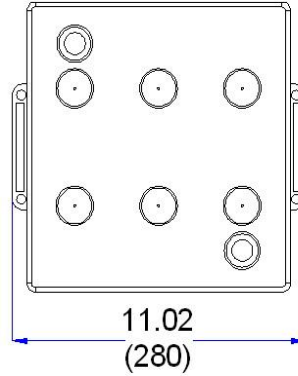

6TN Product Specifications

Type	Capacity Minutes		Cranking Performance		5Hr Rate AH	20Hr Rate AH	Voltage	Dimensions inches(mm)			Weight Lbs (kg)
	@25 Amps	@75 Amps	CCA @-18°C	CA @25°C				L	W	H	
6TN	180	50	600	760	81	100	12	11.02 (280)	10.43 (265)	9.06 (230)	44.66 (20.3)

Characteristics

Internal Resistance	Capacity affected by Temperature (20hour rate)				Charge (Constant Voltage)	
Full Charge Battery 77°F(25°C)	104°F (40°C)	77°F (25°C)	32°F (0°C)	5°F (-15°C)	Float Charge	Equalize Charge
3.9mΩ	102%	100%	85%	64%	13.6V~13.8V	14.7V~15.5V